

INSTRUCTIONS



WEATHER - BRAKE

307022161

FITS

John Deere 5220 & 5320



General Offices
1132 W. 1ST STREET
McPherson, KS 67460
Phone: (620) 241-3513
Web: www.femcomfg.com

Form No. 286316300 09/2004

IMPORTANT

CAREFULLY STUDY THE PHOTO DIAGRAMS SHOWING THE LOCATION OF EACH PART. LEAVE ALL HARDWARE LOOSE UNTIL INSTRUCTED TO TIGHTEN.

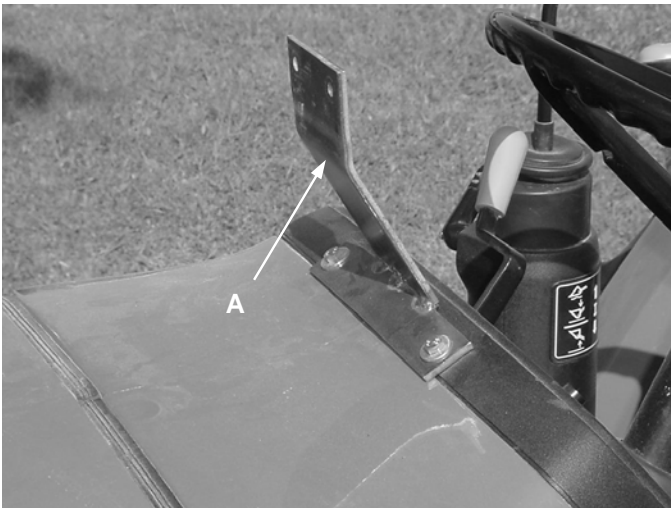

YOKE BRACKET

1. Remove two (2) bolts from top of dash.
2. Attach yoke bracket (A) to top of dash using two (2) M6 x 25 mm bolts and washers.
3. Tighten Bolts

DOOR POST

1. Remove bolt from location (B) on left foot rest.
2. Drill out a 9/32" hole.
3. Attach door post (A) to foot rest using one (1) 1/4" x 1 1/2" bolt and nut.

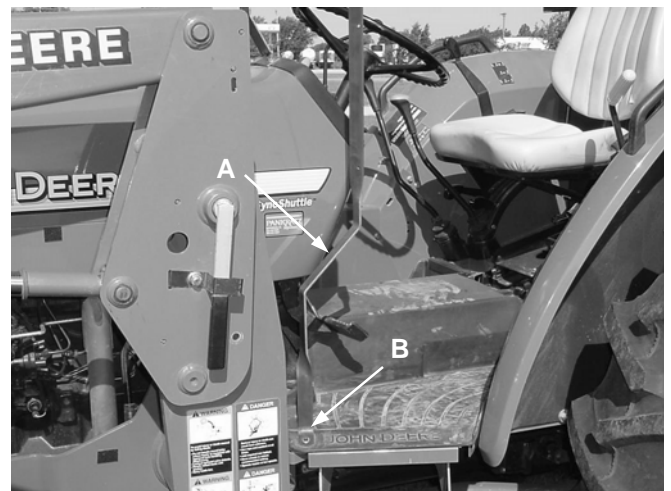



MOTOR COVER

1. Insert 3" hem on left side of motor cover down over door post.
2. Arrange motor cover over top of hood and down sides.

YOKE

1. Insert yoke (A) into top 3" hem of motor cover.
2. Attach yoke to yoke bracket using two (2) 1/4" x 3/4" bolts and nuts. Heads of bolts to outside nuts inside.
3. Attach left side of yoke to top of door post using one (1) 1/4" x 1" bolt and nut. Head of bolt to inside, nut outside.



SIDE ARM

1. Insert side arm (A) into side 3" hem of motor cover
2. Attach front of side arm to right side of yoke using one (1) 3/8" x 1" bolt and nut. Head of bolt up, nut down.
3. Position rear of side arm on fender and drill a 9/32" diameter hole.
4. Attach rear of side arm to fender using one (1) 1/4" x 1" bolt and nut.
5. Tighten all bolts.

WINDSHIELD ASSEMBLY

1. Attach left and right window frames using two (2) #10 x 1/2" bolts and nuts.
2. Slide glass into the channel of the windshield.
3. Attach flat strip and angle strip to the windshield using two (2) #10 x 1/2" bolts and nuts.

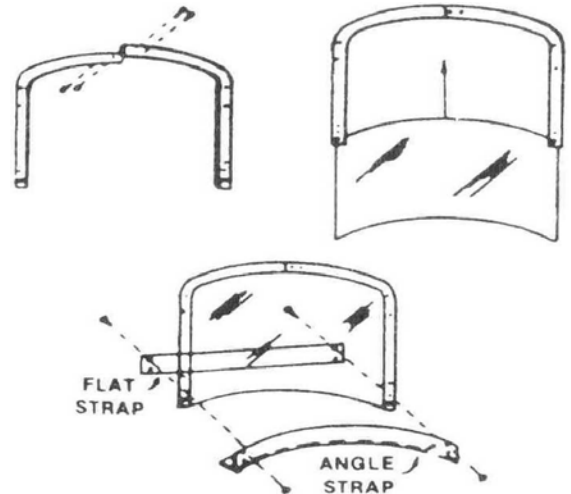

WINDSHIELD ATTACHMENT

1. Remove nut from left side of yoke and door post and attach assembled windshield
2. Attach other side of windshield to yoke using one (1) 1/4" x 1" bolt and nut.
3. Tighten bolts.

Dual Lock® a registered trademark of 3M Co.

1. Cut plastic Dual Lock into 2" lengths.
2. Surface must be cleaned with a mild detergent to assure proper application of Velcro strips.

NOTE: Do not peel the backing from the Dual Lock.

3. Apply cut Dual Lock to all Dual Lock sewn to motor cover.
4. Arrange motor cover to tractor. Peel backing from Dual Lock and apply to tractor. Repeat this procedure for all Dual Lock.





DOOR

1. Locate holes in door post and cut holes in fabric.
2. Hold door (A) to door post and bottom of windshield.
3. Mark location of holes in door post to door.
4. Cut 5/8" slots next to wire frame of door and attach to door posts using two (2) #10 x 3/4" bolts, clips and nuts.
5. Tie door flap (B) to straps on motor cover.
6. Tighten bolts.

LEFT WINDOW

1. Mark location holes in windshield to left window (A).
2. Cut 5/8" slots next to wire frame of left window and attach to windshield using two (2) #10 x 3/4" bolts and nuts.
3. About 6" from back of left window at location (B) cut 5/8" slots in left window and door and attach using one (1) #10 x 3/4" bolt, nut & clip.
4. Tighten bolts.

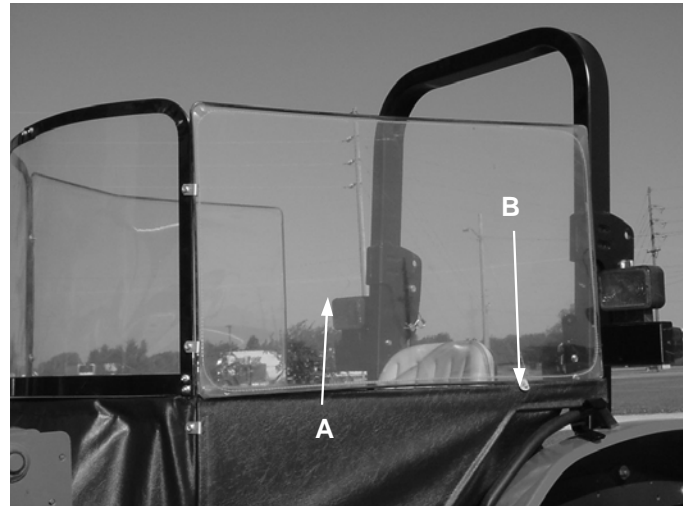

RIGHT WINDOW

1. Right window (A) is to be bent to match configuration of yoke and side arm.
2. Using same procedure as left window, attach right window to windshield.
3. Mark location of hole in side arm to bottom of right window and using same procedure as left window, attach to side arm.
4. Tighten bolts.

DOOR LATCH

1. Assemble door latches as shown using two (2) 1/4" x 3/4" bolts and nuts.
2. Position under bottom of rear door.
3. Door is to set firmly in loop of door latch. Change position up or down with adjustment holes if necessary.
4. Mark location for one (1) of the two (2) holes and drill one (1) 9/32" diameter hole.
5. Attach to fender using one (1) 1/4" x 1" bolt and nut.
6. Tighten all bolts.



TIE STRAP

IMPORTANT: Cloth straps are not to be attached to any moving, rotating, or heat generating points of the tractor. Any excess cloth straps are to be cut off.

1. Tie cloth strap to one side of front bottom grommet of motor cover.
2. Route under tractor and tie to other grommet on other side.

REPLACEMENT PARTS

| | | |
|-----|-----------|-----------------------|
| 1. | 711230601 | Bracket Latch Door |
| 2. | 711230701 | Latch Door |
| 3. | 711389800 | Windshield |
| 4. | 720941101 | Yoke Bracket |
| 5. | 711832401 | Side Arm |
| 6. | 711832301 | Door Post |
| 7. | 712101801 | Yoke |
| 8. | 712181101 | Windshield Frame R.H. |
| 9. | 712181201 | Windshield Frame L.H. |
| 10. | 712181301 | Bottom Angle |
| 11. | 712181401 | Windshield Flat |
| 12. | 720735000 | Side Window |
| 13. | 720940901 | Motor Cover |
| 14. | 720941001 | Door |

NOTES